



MEDmobility
 5711- Calgary Trail NW
 Edmonton AB T6H 2K1
 Phone (800) 981-1111 P:780-437-3300 • F:780-430-9381
 sales@kimobility.com AADL Vendor # 0000612578-001

ROGUE ALX HD AADL

Discount is 8%

AADL #W154C

Effective 07/18/2022

Company: _____

Ship To: _____

Account Number: _____ Date: _____

Address: _____

Quote PO Number: _____

City: _____ State: _____

RTS: _____

Zip: _____ Phone: _____

Marked For: _____

Email/Fax: _____

Rogue ALX **\$3090**
 350 lb weight capacity

Frame

Seat Width / Seat Depth

Select box corresponding to desired Seat Width and Depth. See references A and B on page 6.

		Seat Width						
		16"	17"	18"	19"	20"	21"	22"
Price		N/C	N/C	N/C	N/C	N/C	N/C	N/C
Seat Depth	16"	N/C	<input type="checkbox"/>	<input type="checkbox"/>	<input type="checkbox"/>	<input type="checkbox"/>	<input type="checkbox"/>	<input type="checkbox"/>
	17"	N/C	<input type="checkbox"/>	<input type="checkbox"/>	<input type="checkbox"/>	<input type="checkbox"/>	<input type="checkbox"/>	<input type="checkbox"/>
	18"	N/C	<input type="checkbox"/>	<input type="checkbox"/>	<input type="checkbox"/>	<input type="checkbox"/>	<input type="checkbox"/>	<input type="checkbox"/>
	19"	N/C	<input type="checkbox"/>	<input type="checkbox"/>	<input type="checkbox"/>	<input type="checkbox"/>	<input type="checkbox"/>	<input type="checkbox"/>
	20"	N/C	<input type="checkbox"/>	<input type="checkbox"/>	<input type="checkbox"/>	<input type="checkbox"/>	<input type="checkbox"/>	<input type="checkbox"/>

Sling Position

In Performance Position (0"), sling is at front of frame. The 1" or 2" sling position extends the frame in front of the sling by that amount. See reference C on page 6.

- 0" (Performance) _____ N/C
- 1" _____ N/C
- 2" (Classic) _____ N/C

Adjustable Depth

Adds the capability to grow seat in depth

- No Rear Adjustment _____ N/C
- 1/2" _____ N/C
- 1" _____ N/C
- 2" _____ N/C
- 3" _____ N/C

Long Sling

Available only with 1", 2" and 3" Adjustable Depth

- Long Sling _____ N/C
Sling will be maximum 2" longer than seat depth

Front Frame Bend

Angle between front seat tube and ground. See reference D on page 6.

- 80° _____ N/C
- 75° _____ N/C
- 70° _____ N/C

Backrest

Back Post / Height Range / Back Height

Select Back Height in row corresponding to desired Back Post and Height Range

Back Post	Price	Height Range	Back Height				
Height Adjustable	N/C	Short	<input type="checkbox"/> 11	<input type="checkbox"/> 12	<input type="checkbox"/> 13	<input type="checkbox"/> 14	
		Medium	<input type="checkbox"/> 13	<input type="checkbox"/> 14	<input type="checkbox"/> 15	<input type="checkbox"/> 16	<input type="checkbox"/> 17
		Tall	<input type="checkbox"/> 17	<input type="checkbox"/> 18	<input type="checkbox"/> 19	<input type="checkbox"/> 20	
Fixed ** Height ¹	\$63		<input type="checkbox"/> 9	<input type="checkbox"/> 10	<input type="checkbox"/> 11	<input type="checkbox"/> 12	<input type="checkbox"/> 13
			<input type="checkbox"/> 14	<input type="checkbox"/> 15	<input type="checkbox"/> 16	<input type="checkbox"/> 17	<input type="checkbox"/> 18

¹ Not available with back upholstery

Push Handle

- Omit Push Handle _____ N/C
- Standard Push Handle _____ N/C
- Bolt-On Push Handle ** _____ \$156
Handles will be 1" - 2" above back height

Backrest continued

Rigidizer Bar

Adjustable Height Rigidizer Bar ** _____ \$94

Seat Back Angle

Standard is 90° (perpendicular to floor). Minus (-°) closes back angle. Plus (+°) opens back angle.

- Standard +3° +6° +9°
 -3° -6° -9° -12°

Back Upholstery

Available only with Height Adjustable Back Posts

- Tension Adjustable _____ \$175
 Omit Back Upholstery _____ N/C

Front Seat Height and Casters

Caster Size / Footrest Taper / Front Seat Height

Select Front Seat Height in row corresponding to Footrest Taper and Caster Size.
Footrest Taper indicates bend of front frame creating footrest width. Taper is measured from outside of seat frame to outside of front tube. 2" Taper not available with 70° or 75° Front Frame Bend. Taper is not available with 70° Front Frame Bend. See reference E on page 6.
Front Seat Height is measured from floor to top of seat tube at front of seat sling. Adjustable up or down by 1/2". See reference F on page 6.

Footrest Taper	Caster Size	Front Seat Height											
		<input type="checkbox"/> 15	<input type="checkbox"/> 15.5	<input type="checkbox"/> 16	<input type="checkbox"/> 16.5	<input type="checkbox"/> 17	<input type="checkbox"/> 17.5	<input type="checkbox"/> 18	<input type="checkbox"/> 18.5	<input type="checkbox"/> 19	<input type="checkbox"/> 19.5	<input type="checkbox"/> 20	<input type="checkbox"/> 20.5
Straight	6"	<input type="checkbox"/>	<input type="checkbox"/>	<input type="checkbox"/>	<input type="checkbox"/>	<input type="checkbox"/>	<input type="checkbox"/>	<input type="checkbox"/>	<input type="checkbox"/>	<input type="checkbox"/>	<input type="checkbox"/>	<input type="checkbox"/>	<input type="checkbox"/>
1" Taper	6"	<input type="checkbox"/>	<input type="checkbox"/>	<input type="checkbox"/>	<input type="checkbox"/>	<input type="checkbox"/>	<input type="checkbox"/>	<input type="checkbox"/>					
2" Taper	6"	<input type="checkbox"/>	<input type="checkbox"/>	<input type="checkbox"/>	<input type="checkbox"/>	<input type="checkbox"/>	<input type="checkbox"/>	<input type="checkbox"/>					

Caster Type

- 1" Poly _____ N/C
 1" Pneumatic _____ \$100
 1.5" Poly _____ \$63
 1.5" Soft Roll Aluminum _____ \$250

Fork Options

- Slotted Fork _____ Std
 Caster Pin Locks ** _____ \$244
Available only with Slotted Fork

Footrest

- Footplate**
- Tubular "Open" Footplate _____ Std
*Not available with footrest widths greater than 17.5".
 See Reference G on page 6.*
 - Tubular Footplate with ABS Cover _____ N/C
*Not available with footrest widths greater than 15.5".
 See Reference G on page 6.*
 - Aluminum Angle Adjustable _____ \$119

Seat to Footrest Length

Measured from front edge of seat sling to top, rear of footrest. Footrest length at least 2.5" shorter than Front Seat Height recommended. See reference H on page 6.

<input type="checkbox"/> 8"	<input type="checkbox"/> 8.5"	<input type="checkbox"/> 9"	<input type="checkbox"/> 9.5"	<input type="checkbox"/> 10"	<input type="checkbox"/> 10.5"
<input type="checkbox"/> 11"	<input type="checkbox"/> 11.5"	<input type="checkbox"/> 12"	<input type="checkbox"/> 12.5"	<input type="checkbox"/> 13"	<input type="checkbox"/> 13.5"
<input type="checkbox"/> 14"	<input type="checkbox"/> 14.5"	<input type="checkbox"/> 15"	<input type="checkbox"/> 15.5"	<input type="checkbox"/> 16"	<input type="checkbox"/> 16.5"
<input type="checkbox"/> 17"	<input type="checkbox"/> 17.5"	<input type="checkbox"/> 18"	<input type="checkbox"/> 18.5"	<input type="checkbox"/> 19"	<input type="checkbox"/> 19.5"

Footrest Protector

- Footrest Protector ** _____ \$32
Not available with Angle Adjustable Flip Under, High Mount Angle Adjustable Flip Under or High Mount Aluminum Angle Adjustable Footplates

Rear Seat Height and Wheels

Wheel Size / Rear Seat Height

Select Rear Seat Height in row corresponding to desired Wheel Size. For proper setup, selection is required when omitting rear wheels. Measured from floor to top of seat tube at front of back post. Rear Seat Height is custom to needs. See reference I on page 6.

Wheel Size	Rear Seat Height															
20"	<input type="checkbox"/> 12.5 ¹	<input type="checkbox"/> 13	<input type="checkbox"/> 13.5	<input type="checkbox"/> 14	<input type="checkbox"/> 14.5	<input type="checkbox"/> 15	<input type="checkbox"/> 15.5	<input type="checkbox"/> 16	<input type="checkbox"/> 16.5	<input type="checkbox"/> 17	<input type="checkbox"/> 17.5	<input type="checkbox"/> 18	<input type="checkbox"/> 18.5	<input type="checkbox"/> 19	<input type="checkbox"/> 19.5	<input type="checkbox"/> 20
22"	<input type="checkbox"/> 13.5 ¹	<input type="checkbox"/> 14	<input type="checkbox"/> 14.5	<input type="checkbox"/> 15	<input type="checkbox"/> 15.5	<input type="checkbox"/> 16	<input type="checkbox"/> 16.5	<input type="checkbox"/> 17	<input type="checkbox"/> 17.5	<input type="checkbox"/> 18	<input type="checkbox"/> 18.5	<input type="checkbox"/> 19	<input type="checkbox"/> 19.5	<input type="checkbox"/> 20		
24"	<input type="checkbox"/> 14.5 ¹	<input type="checkbox"/> 15	<input type="checkbox"/> 15.5	<input type="checkbox"/> 16	<input type="checkbox"/> 16.5	<input type="checkbox"/> 17	<input type="checkbox"/> 17.5	<input type="checkbox"/> 18	<input type="checkbox"/> 18.5	<input type="checkbox"/> 19	<input type="checkbox"/> 19.5	<input type="checkbox"/> 20				
25" **	<input type="checkbox"/> 15 ¹	<input type="checkbox"/> 15.5	<input type="checkbox"/> 16	<input type="checkbox"/> 16.5	<input type="checkbox"/> 17	<input type="checkbox"/> 17.5	<input type="checkbox"/> 18	<input type="checkbox"/> 18.5	<input type="checkbox"/> 19	<input type="checkbox"/> 19.5	<input type="checkbox"/> 20					
26" **	<input type="checkbox"/> 15.5 ¹	<input type="checkbox"/> 16	<input type="checkbox"/> 16.5	<input type="checkbox"/> 17	<input type="checkbox"/> 17.5	<input type="checkbox"/> 18	<input type="checkbox"/> 18.5	<input type="checkbox"/> 19	<input type="checkbox"/> 19.5	<input type="checkbox"/> 20						

¹ Available only with Low Profile Rear Tire Type

Camber Bar Tower

- Standard Tower _____ N/C
- Mx Tower ** _____ \$156

Standard Tower allows rear seat height adjustment up or down in 1/4" increments. 1" adjustment available; 1/2" in lowest end of range. **Mx Tower** required with select low seat heights or when large rear seat height adjustment range is required. Provides 3" adjustment range in 1/4" increments.

Rear Wheel Type

- Spoke _____ N/C
 - Mag _____ \$63
Not available in 25" or 26" rear wheels
 - Spinergy Spox ** _____ \$795
Not available in 20" rear wheel
- Color: Black Red White Blue Yellow
- Handrim: Short Tab Long Tab
Available only with Aluminum Anodized and Plastic Coated Handrims

Rear Tire Type

Full Profile

- Street Pneumatic 1 3/8" _____ Std
Not available on 25" rear wheel
- Full Poly 1 3/8" _____ \$69
Not available on 25" rear wheel
- Pneumatic with Airless Insert 1 3/8" ** _____ \$125
Not available on 25" rear wheel
- Schwalbe HS-127 1 3/8" ** _____ \$119
Available only on 24" rear wheel. Not available on Mag wheels.
- Euro Trek Knobby 1 3/8" ** _____ \$119
Available only on 24" rear wheel
- Mountain 2" Black ** _____ \$156
Available only on 22", 24" and 25" Spoke and Spinergy wheels

Low Profile

- Sentinel Solid Tire 1" ** _____ \$119
Not available on 20" and 22" Mag wheels
- High Pressure 1" ** _____ \$75
Not available on Mag wheels
- Schwalbe One 1" ** _____ \$135
Available only on 24" and 25" rear wheels. Not available on Mag wheels.
- Schwalbe Marathon Plus Evolution 1" ** _____ \$156
Not available on Mag, 20" or 22" rear wheels

Rear Seat Height and Wheels continued

Handrim

Standard Handrims

- Aluminum Anodized _____ Std
- Plastic Coated _____ \$119
- Projection (8 Vertical Projections) _____ \$299
Available on 22", 24", 25" and 26" Spoke wheels & 24" Mag wheels w/full tires.
 Clinical justification required.
- Omit Handrim _____ N/C

Natural Fit Handrims

Not available on 20" rear wheel or 22" Mag wheels. Not recommended with Mag wheels.

- Natural Fit LT Regular Grip ** _____ \$445
- Natural Fit Standard Regular Grip ** _____ \$445
- Natural Fit LT Super Grip ** _____ \$495
- Natural Fit Standard Super Grip ** _____ \$495
- Natural Fit LT Omit Grip ** _____ \$345
- Natural Fit Standard Omit Grip ** _____ \$345

Handrim Option

- 3M Micro Grip ** _____ \$81
Not available on Plastic Coated or Projection Handrims

Axle

- Quick Release _____ Std
- Quad Quick Release _____ \$231
Not available with Mag wheels

Wheel Locks

Wheel Lock

- Push to Lock _____ Std
- Push to Lock Flush Mount _____ N/C
- Pull to Lock _____ N/C
- Under Seat Scissor Lock _____ N/C
- Low Profile Scissor Lock _____ \$35
Not available with Full Poly or Sentinel Solid tires
- Short Thro Scissor Lock ** _____ \$156
- Omit Wheel Locks _____ N/C

Armrests

Armrest Please select Arm Pad option

- Height Adjustable T-Arm (8.5" - 13.5") _____ \$325
1.5" minimum Rear Wheel Spacing
- Height Adjustable T-Arm Low (7.5" - 11.5") _____ \$325
1.5" minimum Rear Wheel Spacing

Arm Pad

Not available with Swing Away Armrests

- Desk Full

Center of Gravity Preset

Measured from front of back post to center of rear axle. 0" indicates axle will be directly under back post. See reference J on page 6.

Amputee Positions

<input type="checkbox"/> -1.5"	<input type="checkbox"/> -1.25"	<input type="checkbox"/> -1"	<input type="checkbox"/> -.75"
<input type="checkbox"/> -.5"	<input type="checkbox"/> -.25"	<input type="checkbox"/> 0"	<input type="checkbox"/> .25"

Standard Positions

<input type="checkbox"/> .5"	<input type="checkbox"/> .75"	<input type="checkbox"/> 1"	<input type="checkbox"/> 1.25"
<input type="checkbox"/> 1.5"	<input type="checkbox"/> 1.75"	<input type="checkbox"/> 2"	<input type="checkbox"/> 2.25"
<input type="checkbox"/> 2.5"	<input type="checkbox"/> 2.75"	<input type="checkbox"/> 3"	<input type="checkbox"/> 3.25"
<input type="checkbox"/> 3.5"	<input type="checkbox"/> 3.75"	<input type="checkbox"/> 4"	<input type="checkbox"/> 4.25"

Rear Wheel Spacing

Measured from outside of back to inside of rear tire. Adjustable out 1/2" from setting. 1.5" minimum Rear Wheel Spacing with Height Adjustable T-Arm Armrest. 1" minimum Rear Wheel Spacing with 0" Rear Wheel Camber. See reference K on page 6.

- .75" 1" 1.25" 1.5" 1.75"

Rear Wheel Camber

- 0° 2° 4° 6° 8°

Wheel Lock Options

- Extension Handles _____ \$84
Available only with Push to Lock or Pull to Lock Wheel Locks
- Grade Aids _____ \$187
Available only with Push to Lock Wheel Locks and Pneumatic or Pneumatic with Airless Insert Rear Tire Types

Armrest continued

- Swing Away (8.5" - 12.5") _____ \$195
Not available with Arm Pads
- Swing Away with Side Guard (8.5" - 12.5") ** _____ \$395
Includes direct mount receiver. Not available with Arm Pads.
- Omit Armrests _____ N/C

Side Guards

Removable Side Guards

Not available with T-Arm Armrests

- Composite Side Guards - Direct Mount Receiver _____ \$175
- Composite Side Guards - Clamp-on Receiver _____ \$200
- Fender Side Guards ** _____ \$350
Includes clamp-on receiver

Accessories

Anti-Tip

- Rear Anti-Tips _____ \$140

Calf Strap

- Velcro Adjustable _____ \$59
- Padded Velcro Adjustable ** _____ \$85
- Bodypoint Padded AeroMesh ** _____ \$123

Positioning Belt

- 1 1/2" Auto Buckle _____ \$22
- 1 1/2" Padded Auto Buckle ** _____ \$170
- 1" Auto Buckle ** _____ \$80
- 1" Padded Auto Buckle ** _____ \$170
- 2" Airline Buckle ** _____ \$150
- Bodypoint Evoflex - Pelvic Stabilizer ** _____ \$219
 Size: Small (16-24") Medium (19-29") Large (25-37")

Belt Mounting Kit

- Ki Mobility Belt Mounting Clamp _____ \$50
Required to mount ASB
- Bodypoint Belt Mounting Bracket Kit ** _____ \$126

Frame Color

Gloss Finish

- Black _____ N/C
- Blue _____ N/C

Seat Pan

- Solid Seat Pan ** _____ \$245
Seat Pan is 1" longer when Long Sling option is selected

Other Accessories

- Tool Kit ** _____ \$45
- Removable Underseat Pouch ** _____ \$50
- Ki Mobility Backpack ** _____ \$65
- Luggage Carrier ** _____ \$120
- Black Neoprene Impact Guards ** _____ \$85
- Under Chair Carrier and Removable Bag ** _____ \$85
- Clear Spoke Guards ** _____ \$144
Not available with Mag wheels
- Black Spoke Guards ** _____ \$144
Not available with 20" rear wheel or Mag wheels
- Cane and Crutch Holder ** _____ \$195

References

A. Seat Width See Diagram 1

Measured from outside of frame tube on one side to outside of frame tube on other side.

B. Seat Depth See Diagram 3

Measured from front of back posts to front edge of seat sling. Seat sling starts at beginning of bend at front of frame.

C. Sling Position See Diagram 2

In Performance Position (0°), sling is at front of frame to keep chair shorter and more maneuverable. The 1" or 2" seat sling position extends the frame in front of the sling by that amount. Adding more frame can improve stability and provide support to aid in transfers.

D. Front Frame Bend See Diagram 3

Angle between front seat tube and ground.

E. Footrest Taper See Diagram 1

Indicates bend of front frame creating footrest. Taper is measured from outside of seat frame to outside of front tube.

F. Front Seat Height See Diagram 1

Measured from floor to top of seat tube at front of seat sling.

G. Footrest Width See Diagram 1

Measured from inside of front tube to inside of front tube on other side. Footrest width is listed below for each seat width and taper.

Seat Width	Straight	1" Taper	2" Taper
Outside Measurement	2" Narrower than Seat Width	4" Narrower than Seat Width	6" Narrower than Seat Width
16"	13.5"	11.5"	9.5"
17"	14.5"	12.5"	10.5"
18"	15.5"	13.5"	11.5"
19"	16.5"	14.5"	12.5"
20"	17.5"	15.5"	13.5"
21"	18.5"	16.5"	14.5"
22"	19.5"	17.5"	15.5"

H. Seat to Footrest Length See Diagram 3

Measured from front edge of seat sling to top rear of footrest. Footrest length of at least 2.5" shorter than front seat height recommended.

I. Rear Seat Height See Diagram 3

Measured from floor to top of seat tube at front of back post. Rear seat height is custom to needs.

J. Center of Gravity Preset See Diagram 3

Measured from front of back post to center of rear axle. 0" indicates axle will be directly under back post.

K. Rear Wheel Spacing See Diagram 1

Measured from outside of seat back to inside of rear tire. Adjustable out .5" from setting.

Diagram 1

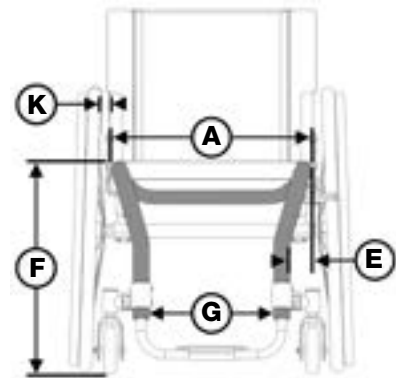

Diagram 2

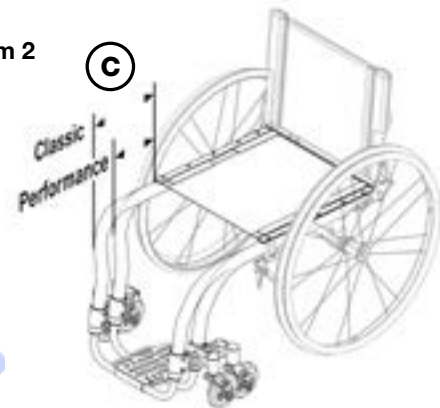

Diagram 3

