

REQUIRED INFORMATION

Date of Order: _____ Dealer Account: _____
 Dealer Name: _____
 PO #: _____
 Purchasing Contact: _____
 Phone: _____ Fax: _____
 E-mail: _____
 RTS/Therapist: _____
 Ship to Address: _____
 City: _____ Province: _____
 Postal Code: _____ Client Gender: M F
 Special Client Conditions: _____

MEDm&bility
 5711- Calgary Trail NW
 Edmonton AB T6H 2K1
 P: 780-437-3300 • F: 780-430-9381
AADL Vendor # 0000612578-001
Discount 6%

REQUIRED MEASUREMENTS

To ensure system is accurately configured please fill in all required

Client Height:	
Client Weight (lbs):	
A. Seat to Shoulder:	
B. Trunk Depth:	
C. Chest Width:	
D. Knee to Back:	
E. Seat to Top of Head:	
F. Elbow to Hand:	
G. Seat to Elbow:	
H. Hip Width:	
I. Knee to Heel:	
Cushion Thickness:	

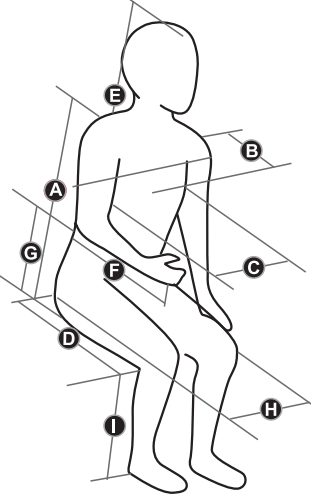

Customer Service: 1.866.748-7943 | Fax: 1.905.695.0583 | www.motionconcepts.com

INVACARE POWER BASES

<input type="checkbox"/> TDXSP2	TDX-SP2 Base	\$7,575
Select STF ⁽¹⁾ :	SLOW <input type="checkbox"/> 16.75" ⁽²⁾	\$250
	LOW <input type="checkbox"/> 17.25"	
	MED <input type="checkbox"/> 18.25"	
	TALL <input type="checkbox"/> 19.25"	

1. Seat-to-floor height is measured at the front of the seat pan based on a standard seat size.
 2. Must order 24TRY battery tray type and Transport Brackets TRBKTS. Only available on 17" seat depths and greater.

USER WEIGHT LIMITS

<input type="checkbox"/> U300	Weight Capacity up to 300 lbs	STD
-------------------------------	-------------------------------------	-----

PERFORMANCE MOTORS

<input type="checkbox"/> HSMTR	Performance Motors - 7.5 mph ⁽¹⁾	\$995
--------------------------------	---	-------

1. Must order 24TRY Battery Tray Type

TRANSPORT TIE DOWN

<input type="checkbox"/> TRBKTS	Wheelchair Transport Brackets ⁽¹⁾	STD
---------------------------------	--	-----

1. For unoccupied use only

TIRE OPTIONS

<input type="checkbox"/> B1431-3	14" x 3" Black Tire with Gel Foam Inserts	STD
<input type="checkbox"/> B1430-3T	14" x 3" Black Tire - Pneumatic Tire	N/C

FORK OPTIONS

<input type="checkbox"/> DSFK	Double-Sided Fork Package	STD
<input type="checkbox"/> FKPKG	Single-Sided Fork Package	\$375

BATTERY TRAY TYPE

<input type="checkbox"/> 22TRY	22NF Style Tray - Narrow Base 24"	N/C
<input type="checkbox"/> 24TRY	Group 24 Style Tray - Standard Base 25.5"	N/C

FRAME FINISH

<input type="checkbox"/> 163P	Black Ice Glossy	N/C
<input type="checkbox"/> 162P	Space Station Silver	N/C
<input type="checkbox"/> 160P	Invacare Blue	N/C
<input type="checkbox"/> 158P	Lights Out Black Matte	N/C
<input type="checkbox"/> 154P	Rockstar Red	N/C
<input type="checkbox"/> 155P	Tangy Orange	N/C
<input type="checkbox"/> 161P	Grape Jelly Bean	N/C
<input type="checkbox"/> 157P	Island Blue	N/C
<input type="checkbox"/> 156P	Monster Green	N/C
<input type="checkbox"/> 159P	White Out	N/C

RIM INSERT COLORS - MUST PICK ONE

<input type="checkbox"/> 163PR	Black Ice Glossy	N/C
<input type="checkbox"/> 162PR	Space Station Silver	N/C
<input type="checkbox"/> 160PR	Invacare Blue	N/C
<input type="checkbox"/> 158PR	Lights Out Black Matte	N/C
<input type="checkbox"/> 154PR	Rockstar Red	N/C
<input type="checkbox"/> 155PR	Tangy Orange	N/C
<input type="checkbox"/> 161PR	Grape Jelly Bean	N/C
<input type="checkbox"/> 157PR	Island Blue	N/C
<input type="checkbox"/> 156PR	Monster Green	N/C
<input type="checkbox"/> 159PR	White Out	N/C



Maxx Rehab Seat on Invacare TDX-SP2 Base

Dealer Name: _____

Dealer Account Number: _____

PO #: _____

Tag: _____

LIGHTS AND INDICATORS

LIGHTS LED Lights and Indicators⁽¹⁾ \$995

1. Must order REM216, REM400 or REM500

CONTROLLERS

EXPC Expandable Controller STD

GTRAC-LX LiNX G-TRAC Module \$1,200

REM110 LiNX Drive Only Remote/Joystick STD

REM210 LED Non-Expandable Remote/Joystick STD

Three drive function, control of single/dual actuator through drive control.

1. Lights are not available with non-expandable remote.

EXPANDABLE DRIVE CONTROL

REM211 LED Expandable Remote/Joystick⁽¹⁾⁽²⁾ \$875
Three drive functions, control of up to 6 actuators through the drive control. Not for use with specialty controls.

REM216 LED Expandable Remote/Joystick with Lights⁽²⁾⁽³⁾ \$875
Three drive functions, control of up to 6 actuators through the drive control and light operation. Not for use with specialty controls.

REM400 Color 3.5" Touch Screen Remote/Joystick⁽²⁾⁽⁴⁾⁽⁵⁾ \$1,100

SW400TGL Toggle Kit for REM400⁽⁶⁾ \$200

REM500 LiNX Color 3.5" Touch Screen Display Only - No Driver Control⁽²⁾⁽³⁾⁽⁴⁾ \$1,100

Select mounting position

R5MR Right

R5ML Left

PWH Harness Required for Expandable System N/C

OUTPUT Output Module \$645

1. Not available with lights and indicators

2. Must choose EXPC Expandable Controller and PWH Harness.

3. Must choose lighting package separately.

4. Can control lighting, must choose lighting package separately.

5. May also be used as display for specialty controls, chose specialty controls separately.

6. Adds 2 toggle switches to REM400.

ATTENDANT DRIVE CONTROL CHOICES

ACU Proportional Attendant Control \$1,024

Select seating style for mounting type

TAM Tilt & Elevate Mount

RAM Recline Mount

Select mounting position

RIGHT-ACU Right

LEFT-ACU Left

SPECIALTY PROPORTIONAL CONTROLS REQUIRES REM400 OR REM500

CREM LiNX Compact Remote⁽¹⁾ \$1,097

CREM-LF LiNX Compact Remote Low Force⁽¹⁾ \$1,097

Select mounting position

MR Right

ML Left

1. Cannot be mounted on the same side as the REM400/REM500

LiNX* DIGITAL CONTROLS SIP-N-PUFF

PKG32666 Therafin Sip-N-Puff Breath Tube Kit \$440

INPUT LiNX Input Module & Sip-N-Puff Interface⁽¹⁾⁽²⁾ (9 Pin Connection) \$1,800

1. Only one input module per chair.

2. This is required with ASL Drive Controls.

MOUNTING FOR DRIVER CONTROLS

FM-ML Fixed Mounting Left N/C

FM-MR Fixed Mounting Right N/C

SAQR Motion Height Adjustable Swing-Away Quad Link (Right Hand) \$344

SAQL Motion Height Adjustable Swing-Away Quad Link (Left Hand) \$344

MRR Maxx Resolve Swing-Away Joystick Mount (Right Hand) \$450

MRL Maxx Resolve Swing-Away Joystick Mount (Left Hand) \$450

LiNX ELECTRONIC ACCESSORIES

LAK LiNX Access Key⁽¹⁾ \$50

MUSB Motion Dual USB Charger N/C

1. Required for programming

JOYSTICK TOPS

PC101A Bodypoint U Shaped Handle 3" \$120

PC102A Bodypoint U Shaped Handle 4" \$120

PC107A Bodypoint Rubber Dome \$120

1560 T Handle Flexible Joystick Extension \$120

1561 Straight Handle Flexible Joystick Extension \$120

1826 Chin Cup \$120

1. To remove/disengage the joystick knob from the REM400 Remote pull straight up on the joystick (DO NOT TWIST) otherwise damage may occur and may void the warranty.

INSTALLATION OF BATTERIES

22NFBATTERY 22 NF Battery (On Chair) \$700

24BATTERY 24 Gel Battery (On Chair) \$840

BATTERY CHARGER OPTION

110CHARGER 110 Volt Battery Charger N/C

L8900 Omit Battery Charger N/C

Maxx Rehab Seat on Invacare TDX-SP2 Base

NOTE: Systems Include Seat Pan, Back Pan, and Standard Armrests. They are designed for use with a 2"-3" cushion

Dealer Name: _____

Dealer Account Number: _____

PO #: _____

Tag: _____

REHAB SEATING SYSTEM

D0195 Maxx Adjustable Rehab Seat \$1,995

ADULT SEAT WIDTH SETTINGS

- SW116 16" Wide (Adjustable from 16" to 20") N/C
- SW117 17" Wide (Adjustable from 16" to 20") N/C
- SW118 18" Wide (Adjustable from 16" to 20") N/C
- SW119 19" Wide (Adjustable from 16" to 20") N/C
- SW120 20" Wide (Adjustable from 16" to 20") N/C
- W219 19" Wide (Adjustable from 19" to 22") \$460
- W220 20" Wide (Adjustable from 19" to 22") \$460
- W221 21" Wide (Adjustable from 19" to 22") \$460
- W222 22" Wide (Adjustable from 19" to 22") \$460

ADULT ULTRA RAIL SEAT DEPTH SETTINGS

- SD116 16" Deep (Adjustable from 16" to 21") N/C
- SD117 17" Deep (Adjustable from 16" to 21") N/C
- SD118 18" Deep (Adjustable from 16" to 21") N/C
- SD119 19" Deep (Adjustable from 16" to 21") N/C
- SD120 20" Deep (Adjustable from 16" to 21") N/C
- D219 19" Deep (Adjustable from 19" to 22") \$460
- D220 20" Deep (Adjustable from 19" to 22") \$460
- D221 21" Deep (Adjustable from 19" to 22") \$460
- D222 22" Deep (Adjustable from 19" to 22") \$460
- D223 23" Deep (Adjustable from 19" to 22") \$460

MATRIX SEATING OPTIONS

- Matrix Cushions available on page 8
- Matrix Backs available on page 9
- Matrix Headrests available on page 10



LAP BELTS

- BELT48 Push Button Style Lap Belt, Length 48" STD
- BELT60 Push Button Style Lap Belt, Length 60" N/C
- BELT71 Push Button Style Lap Belt, Length 71" N/C
- PLB2 Bodypoint Padded Lap Belt 2 Point⁽¹⁾ \$250
- PLB4 Bodypoint Padded Lap Belt 4 Point⁽¹⁾ \$315

1. 67" length only option

MOTION CONCEPTS HEADREST OPTIONS

- MCSH Motion Concepts Standard N/C
- MCOH Motion Concepts Auto Style \$235
- FM Fixed Mounting (non-removable) N/C
- MAHU Motion Concepts Multi-Axis Rem.HDW \$195
- OMIT Omit: Headrest N/C

MATRIX HEADRESTS OPTIONS

- Matrix Elan Headrests and Hardware available on page 9

STANDARD BACK CANES⁽¹⁾

- SBC18 18" Straight Back Canes STD
- SBC20 20" Straight Back Canes STD
- SBC22 22" Straight Back Canes STD
- SBC24 24" Straight Back Canes STD
- TBC18 18" 10° Mid-Angle Canes for Sling Back . . . N/C
- TBC20 20" 10° Mid-Angle Canes for Sling Back . . . N/C
- TBC22 22" 10° Mid-Angle Canes for Sling Back . . . N/C
- TBC24 24" 10° Mid-Angle Canes for Sling Back . . . N/C
- ABC20 20" Angled (5°) Back Canes N/C
- ABC22 22" Angled (5°) Back Canes N/C
- ABC24 24" Angled (5°) Back Canes N/C
- SBCF18 18" Straight Fold Down Back Canes \$250
- SBCF20 20" Straight Fold Down Back Canes \$250
- SBCF22 22" Straight Fold Down Back Canes \$250
- SBCF24 24" Straight Fold Down Back Canes \$250

1. Canes will be set at 90° angle and are adjustable from 75° to 116°

FINISHED BACK HEIGHT⁽¹⁾⁽²⁾

- 18" FBT18
- 19" FBT19
- 20" FBT20
- 21" FBT21
- 22" FBT22
- 23" FBT23
- 24" FBT24
- 25" FBT25

1. 4" Gap from the seat pan to the bottom of back pan is recommended.
2. Finished back height is measured from seat pan to top of backrest.

BACK OPTIONS

- SRB Standard Rehab Back & Cushion \$125
- SLING Sling Back Fabric \$125
- ORBC Omit Rigid Back & Cushion N/C

MATRIX BACKREST OPTIONS

- Matrix Backs available on page 9

Maxx Rehab Seat on Invacare TDX-SP2 Base

Dealer Name: _____

Dealer Account Number: _____

PO #: _____

Tag: _____

ARMRESTS

- DP1 Adult Dual Post Adj. 9.75"-12.75"N/C
- DP2 Adult Dual Post Adj. 12.75"-15.75"N/C
- DP3 Adult Dual Post Adj. 15.75"-18.75"N/C
 - OAL ADD: OutBack Arm Option Left⁽¹⁾ each \$195
 - OAR ADD: OutBack Arm Option Right⁽¹⁾ each \$195
- OCTA1 Outback Cantilever Tilt Armrest 9"-12"⁽³⁾ . . . \$488
- OCTA2 Outback Cantilever Tilt Armrest 12"-15"⁽³⁾ . . \$488
- RMCAN Ultra Rail Seat Mnt Flip Back Cantilever
MAXX Tilt Arm (9-12.5")⁽²⁾ \$488
- DPM ADD: Dual Post Module to RMCAN (pair) \$250

1. Only available with Dual Post Armrests.
 2. Mounts to Seat Rail. Slotted upper tube for infinite fore/aft adjustment of arm pad.
 3. Not available with the Universal Cup Holder or Flip and Fold Lap Tray.

ARMREST TUBE LENGTH - PLEASE SPECIFY

- ATFL Left Full STD
- ATDL Left Desk STD
- ATFR Right Full STD
- ATDR Right Desk STD

ARMPADS

- Standard**
- SAPFL Left Full (2.25" x 14") STD
 - SAPDL Left Desk (2.25" x 10") STD
 - SAPFR Right Full (2.25" x 14") STD
 - SAPDR Right Desk (2.25" x 10") STD

Waterfall Arm Pads⁽¹⁾

- WAPFL Left Full (13") \$50
- WAPDL Left Desk (9") \$50
- WAPFR Right Full (13") \$50
- WAPDR Right Desk (9") . . . \$50

Modular Arm Pad - Left⁽²⁾

- MAPTFL Left Tray Full (14") \$95
- MAPTDL Left Tray Desk (10") \$95

Select Pad Insert below:

- ISSFL Iskin - Integrated soft skin foam
- SCVFL Startex Covered Visco foam

Modular Arm Pad - Right⁽²⁾

- MAPTFR Right Tray Full (14") \$95
- MAPTDR Right Tray Desk (10") \$95

Select Pad Insert below:

- ISSFR Iskin - Integrated soft skin foam
- SCVFR Startex Covered Visco foam

ARMPADS

Flat Multi Position Arm Pads

- MPAFL Left Full (14") \$150
- MPADL Left Desk (10") \$150
- MPAFR Right Full (14") \$150
- MPADR Right Desk (10") \$150

Gel Pads

- GAPNL Narrow Left (2" x 12") \$88
- GAPNR Narrow Right (2" x 12") \$88
- GAPWL Wide Left (3.5" x 12") \$96
- GAPWR Wide Right (3.5" x 12") \$96
- GAPLL Long Left (3.5" x 14") \$103
- GAPLR Long Right (3.5" x 14") \$103

Arm Troughs

- EATL Ergonomic Arm Trough - Left \$121
- EATR Ergonomic Arm Trough - Right \$121
- FHPL Flat Hand Pad - Left⁽³⁾ \$91
- FHPR Flat Hand Pad - Right⁽³⁾ \$91

Arm Pad Storage/Cup Holder⁽⁴⁾

- APSL Left \$295
- APSR Right \$295
- OMIT Omit Armpads(7/8" diameter tube) N/C

1. Full length pad not compatible with the desk length armrest tube if using Ultra Rail mounted Tilt Arms.
 2. Requires interchangeable pad insert.
 3. Must order with ergonomic arm trough.
 4. Not available on the joystick side.

Maxx Rehab Seat on Invacare TDX-SP2 Base

Dealer Name: _____

Dealer Account Number: _____

PO #: _____

Tag: _____

MANUAL CENTER MOUNT FRONT RIGGING

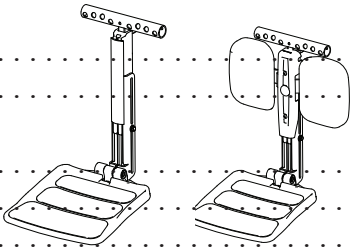
- MSFCMFP Maxx Style Fixed Center Mount Foot Platform⁽¹⁾⁽²⁾ \$395
With Quick Release Height Adjustment
 - IFP Comes with a rubber coated footplate (11.5" W x 10") N/C
 - ICP Individual calf pads \$200
- Select seat pan to footplate:
- SPTF1 9" - 13" N/C
 - SPTF14 13" - 19" N/C
- Set at:
- SA70 Set at 70° N/C
 - SA90 Set at 90° N/C
 - SA97 Set at 97° N/C
- 

1. Depth and height adjustable.
2. 3" ground clearance required.

INVACARE CENTER MOUNT

- IAKACM Invacare Center⁽¹⁾⁽²⁾ "CTMT" \$595
- Select seat pan to footplate:
- SPTF3 9.25" - 12" N/C
 - SPTF14 12.25" - 15" N/C
- Select foot plates/footboard
- SM Individual Foot Plates (5.25"W x 7.5"D) \$165
 - MDM Individual Foot Plates (5.5"W x 9.5"D) \$165
 - LRG Individual Foot Plates (5.9"W x 11.5"D) \$165
 - FB Footboard. \$165
- Optional:
- CALF Invacare Calf Pads for use with CTMT \$268

1. 3" ground clearance required.
2. Not available with the SPTF3 of 9.25"-12"

MAXX STYLE ELEVATING LEGRESTS

- MMPPSA MAXX Swing Away Manual Elevating - Straight⁽¹⁾⁽²⁾ \$680
- Select Receivers:
- RS Straight Receivers N/C
 - RF Flared 1" Outward Receivers N/C
- Select Seat Pan to Footplate:
- SPTF5 Length: 10"-14" N/C
 - SPTF2 Length: 13"-17" N/C
 - SPTF7 Length: 16"-20" N/C
 - FCPMS Flat Calf Pad Option (pair) \$275
 - CCPMS Curved Calf Pad Option (inside with 6")⁽³⁾ (pair) \$275

1. Must choose footplate on page 6
2. Comes standard with moulded i-skin calf pads.
3. Not available on 14 and 15" seat widths. For 16" and 17" seat widths you must select flared receivers.

FOOT PLATFORM OPTIONS FOR MAXX CMFP

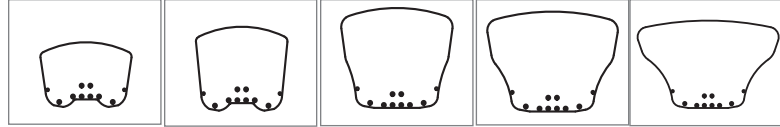

- SFFP Small Foot Platform⁽¹⁾(12"w x 8.5"d) \$180
- MFFP Medium Platform⁽¹⁾ (12"w x 10.75"d) \$180
- LFFP Large Platform⁽¹⁾ (14.5"w x 13"d) \$250
- XLFFP Extra Large Platform⁽¹⁾ (17"w x 13"d) \$250
- XXLFFP Extra Extra Large Platform⁽¹⁾ (21"w x 13"d) \$250

1. May need to adjust leg position to avoid interference with front castors

INDIVIDUAL FOOT PLATES FOR MAXX CMFP

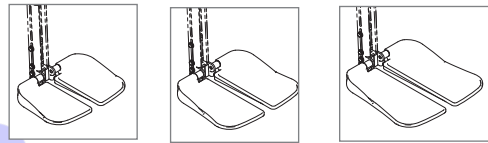

- IFSL Small⁽¹⁾ - (5" x 7.5" deep) - Left \$165
- IFSR Small⁽¹⁾ - (5" x 7.5" deep) - Right..... \$165
- IFML Medium⁽¹⁾ - (5.5" x 9.5" deep) - Left \$165
- IFMR Medium⁽¹⁾ - (5.5" x 9.5" deep) - Right \$165
- IFL Large⁽¹⁾ - (6" x 11.5" deep) - Left..... \$165
- IFLR Large⁽¹⁾ - (6" x 11.5" deep) - Right..... \$165

1. Foot plates may interfere with casters in certain configurations

SWING AWAY LEGREST

- HD70 Heavy Duty 70° Swing Away Footrest(pair)⁽¹⁾⁽²⁾ . \$495
- Select Receivers:
- RS Straight Receivers N/C
 - RF Flared 1" Outward Receivers N/C
- Select Seat Pan to Footplate:
- SPTF11 Length: 6"-10" N/C
 - SPTF8 Length: 11"-15" N/C
 - SPTF2 Length: 13"-17" N/C
 - SPTF7 Length: 16"-20" N/C
 - HDFCP Flat Calf Pad Option (pair) \$275
 - HD70CCP Curved Calf Pad Option⁽³⁾ (inside with 6") (pair) \$275
 - DCS Dynamic Coil Springs (Pair) for Heavy Duty 70° Swingaway Footrests \$190
 - I70SAF Invacare 70° Swingaway Footrests (Pair) \$325
 - I70-CF Comes with composite foot plates N/C
 - I70HDAIH Invacare 70° Non-Tapered HD Swingaway Footrests with AT5543 Adjustable Angle Foot plates, Heel Loops and Impact Guards⁽¹⁾ (Pair) \$457

Dealer Name: _____

Dealer Account Number: _____

PO #: _____

Tag: _____

SWING AWAY LEGREST

- 70TAPAIH Invacare Tapered 70° Swingaway Footrests with AT5543 Adjustable Angle Footplates, Heel Loops and Impact Guards(Pair) \$497
- ALPT Longer Pivot and Slide Tube for 70° Swingaways (Pair) \$132
- RLSL Residual Limb Support - Left⁽⁴⁾ (6.75"W x 9.75"L x 2"H) (each) \$495
- RLSR Residual Limb Support - Right⁽⁴⁾ (6.75"W x 9.75"L x 2"H) (each) \$495

1. Must choose footplate on below.
2. Heavy duty durable construction (4.5lbs ea.).
3. Not available on 14 and 15" seat widths. For 16" and 17" seat widths you must select flared receivers.
4. Swing away and removable, 50° of angle adjustment, 3.5" height adjustment and 2" of for/aft adjustment.

FOOTPLATE SIZE SELECTION

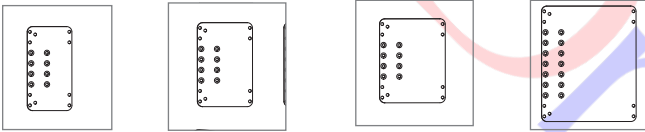

1. Certain footplate sizes may not fit all seat widths depending on legrests selected.

ADJUSTABLE ANGLE FOOTPLATES

- AFSL Left Small Footplate (4.25"W x 8"D) \$165
- AFSLR Right Small Footplate (4.25"W x 8"D) \$165
- AFML Left Medium Footplate (5.25"W x 8"D) \$165
- AFMLR Right Medium Footplate (5.25"W x 8"D) \$165
- AFLL Left Large Footplate (6.25"W x 8"D) \$165
- AFLRL Right Large Footplate (6.25"W x 8"D) \$165
- AFXL Left Extra Large Footplate (9"W x 11"D) \$165
- AFXLR Right Extra Large Footplate (9"W x 11"D) \$165
- HLL Left Heel Loop (each) \$20
- HLLR Right Heel Loop (each) \$20

MULTI-AXIS ADJUSTABLE ANGLE FOOTPLATES

- MFSL Left Small Footplate (4.25"W x 8"D) \$225
- MFSLR Right Small Footplate (4.25"W x 8"D) \$225
- MFML Left Medium Footplate (5.25"W x 8"D) \$225
- MFMLR Right Medium Footplate (5.25"W x 8"D) \$225
- MFLL Left Large Footplate (6.25"W x 8"D) \$225
- MFLLR Right Large Footplate (6.25"W x 8"D) \$225
- MFXL Left Extra Large Footplate (9"W x 11"D) \$225
- MFXLR Right Extra Large Footplate (9"W x 11"D) \$225
- HLL Left Heel Loop (each) \$20
- HLLR Right Heel Loop (each) \$20

FOOTPLATE/CUT OUTS SIZE SELECTION

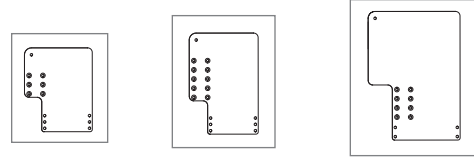

1. Certain footplate sizes may not fit all seat widths depending on legrests selected

ADJUSTABLE ANGLE FOOTPLATES/CUT OUTS

- AFCSL Left Small Footplate (7.25"W x 9"D) \$165
- AFCSR Right Small Footplate (7.25"W x 9"D) \$165
- AFCML Left Medium Footplate (7.5"W x 11"D) \$165
- AFCMR Right Medium Footplate (7.5"W x 11"D) \$165
- AFCLL Left Large Footplate (10"W x 14"D) \$165
- AFCLR Right Large Footplate (10"W x 14"D) \$165
- HLL Left Heel Loop (each) \$20
- HLLR Right Heel Loop (each) \$20

MULTI-AXIS ADJUSTABLE ANGLE FOOTPLATES/ CUT OUTS

- MFCSL Left Small Footplate (7.25"W x 9"D) \$225
- MFCSR Right Small Footplate (7.25"W x 9"D) \$225
- MFCML Left Medium Footplate (7.5"W x 11"D) \$225
- MFCMR Right Medium Footplate (7.5"W x 11"D) \$225
- MFCLL Left Large Footplate (10"W x 14"D) \$225
- MFCLR Right Large Footplate (10"W x 14"D) \$225
- HLL Left Heel Loop (each) \$20
- HLLR Right Heel Loop (each) \$20

THORACIC LATERALS AND HIP/KNEE SUPPORTS

- Matrx Laterals please see page 10
- Maxx Laterals and Hip/Knee supports please see page 11



Maxx Rehab Seat on Invacare TDX-SP2 Base

Dealer Name: _____

Dealer Account Number: _____

PO #: _____

Tag: _____

ADDITIONAL OPTIONS & ACCESSORIES

- NAO2H Non-Articulating O₂ Gas Holder⁽¹⁾ \$395
- NAIPL Non-Articulating IV Pole User's Left. \$395
- NAIPR Non-Articulating IV Pole User's Right . . . \$395
- THS Transfer Handles 4" - 6.5" \$350
- THL Transfer Handles 9" - 11.5" \$350
- FFLTL Flip and Fold Away 1/2 Lap Tray
Left Mounting(14"W x 10"D)⁽²⁾⁽³⁾ \$795
- FFLTR Flip and Fold Away 1/2 Lap Tray
Right Mounting(14"W x 10"D)⁽²⁾⁽³⁾ \$795

- 1. Client weight capacity is 225 lbs when using an O₂ holder. The maximum weight capacity of the O₂ holder is 20 lbs.
- 2. Not available on joystick side and only available with a flat arm pad or modular arm pad.
- 3. The maximum weight capacity of the tray is 10 lbs.

MOTION CONCEPTS SINGLE POST BACKREST

- SPBMI Single Post Angle Adjustable Fold Down
Back interface-Matrx Back⁽¹⁾ (Folds to 25° forward) **\$750**
 Matrx Backs available on page 8
- SPBCI Single Post Angle Adjustable Fold Down
Back for Contour Back⁽¹⁾⁽²⁾ (Folds to 25° forward). . **\$995**
 CB1617 CB1717 CB1817
 CB1917 CB2017
- OCUCB Onyx Fabric Upgrade for Contour Backs . . . \$100

- 1. Single Post Back is an angle adjustable back between 73° and 109° in 6° increments from 17° forward to 19° back. The back folds down and is only available for 16"-20" seat widths & 21"-24" back height. A 4" gap from bottom of back to seat pan is required.
- 2. Includes a Contour Back with fabric cover.

ADDITIONAL ARM ACCESSORIES

- UCH Universal Cup Holder⁽¹⁾ \$35
- MACESL Multi Axis Upper Extremity Support⁽²⁾ (each)
Left Side \$225
- MACESR Multi Axis Upper Extremity Support⁽²⁾ (each)
Right Side \$225
- OAS2L 1" Offset Armrest Spacer Left(each). \$125
- OAS2R 1" Offset Armrest Spacer Right(each). . . \$125
- OAS1L 1/2" Offset Armrest Spacer Left(each). . . \$125
- OAS1R 1/2" Offset Armrest Spacer Right(each). . . \$125
- MPAPA Multi Purpose Arm Pad
Adapter Block⁽³⁾ (each) Quantity () . . . \$35

- 1. Not available on the joystick side.
- 2. Allows rotation of the armpad, only compatible with Gel Arm pad, Flat Arm pad or Ergonomic Arm Troughs.
- 3. Not available with Standard Arm Pads or Waterfall Arm Pad

INSTALLATION

- MCI Installation by Motion Concepts N/C

Total Retail Value \$ _____

PLEASE SPECIFY PAGES INCLUDED

- Pages 1-7 Excludes Matrx and Maxx Seating Accessories
- Pages 1-11 Complete Order Form

NOTES



CUSHION COVER REFERENCE GUIDE

Meshtex	Startex	Infection Control			
Spacetex	Onyx				
Cushion	Meshtex	Startex	Infection	Spacetex	Onyx
Libra/Adjust	N/A	STD	\$50	N/C	N/A
PS/PSP	N/A	STD -Reversible	STD -Reversible	N/A	N/A
Vi	STD	\$103	\$103	N/A	\$103

MATRIX SEAT CUSHION OPTIONS

Matrix Libra Adjust Seat Cushion 16" -20" wide \$985

- LC1416-ADJ LC1516-ADJ LC1518-ADJ LC1520-ADJ
- LC1616-ADJ LC1618-ADJ LC1620-ADJ LC1716-ADJ
- LC1718-ADJ LC1720-ADJ LC1816-ADJ LC1818-ADJ
- LC1820-ADJ LC1916-ADJ LC1918-ADJ LC1920-ADJ
- LC2016-ADJ LC2018-ADJ LC2020-ADJ

Matrix Libra Adjust Seat Cushion 22" depth \$1,265

- LC1622-ADJ LC1722-ADJ LC1822-ADJ
- LC1922-ADJ LC2022-ADJ

Matrix Libra Adjust Seat Cushion 21" - 22" wide \$1,265

- LC2118-ADJ LC2120-ADJ LC2122-ADJ
- LC2218-ADJ LC2220-ADJ LC2222-ADJ

Matrix Libra Seat Cushion 16" - 20" wide \$745

- LC1416 LC1516 LC1518 LC1520 LC1616
- LC1618 LC1620 LC1716 LC1718 LC1720
- LC1816 LC1818 LC1820 LC1916 LC1918
- LC1920 LC2016 LC2018 LC2020

Matrix Libra Seat Cushion 22" deep \$1,025

- LC1622 LC1722 LC1822 LC1922 LC2022

Matrix Libra HD Seat Cushion 21" -22" wide \$1,025

- LC2118 LC2120 LC2122 LC2218 LC2220

Matrix PS Seat Cushion 16" - 20" wide \$569

- PS1416 PS1616 PS1618 PS1620 PS1716
- PS1718 PS1720 PS1816 PS1818 PS1820
- PS2016 PS2018 PS2020

Matrix PS HD Seat Cushion 22" - 22" wide \$975

- PS2218 PS2220 PS2222

Matrix PSVF Seat Cushion 16" - 20" wide \$589

- PSVF1616 PSVF1618 PSVF1620
- PSVF1816 PSVF1818 PSVF1820
- PSVF2016 PSVF2018 PSVF2020

MATRIX SEAT CUSHION OPTIONS

Matrix PSP Seat Cushion 14" - 20" wide \$645

- PSP1416 PSP1616 PSP1618 PSP1620
- PSP1716 PSP1718 PSP1720 PSP1816
- PSP1818 PSP1820 PSP2016 PSP2018
- PSP2020

Matrix Vi Seat Cushion 14" - 20" wide \$624

- MA1415-VI MA1417-VI MA1616-VI MA1618-VI
- MA1620-VI MA1716-VI MA1718-VI MA1720-VI
- MA1816-VI MA1818-VI MA1820-VI MA2016-VI
- MA2018-VI MA2020-VI

Matrix Vi Seat Cushion 21" - 22" wide \$681

- MA2016-VI MA2018-VI MA2020-VI MA2218-VI
- MA2220-VI

Matrix Vi HD Seat Cushion 22" wide \$840

- MA2222-VI

FABRIC OPTIONS FOR CUSHIONS

- SFLF Spacetex Fabric Option for Libra Cushion N/C
- ICFL Infection Control Fabric Upgrade for Libra Cushion \$50
- OCUMA Onyx Fabric Upgrade for Matrix Vi Cushion. \$100
- SFVS Smooth side Startex Fabric Upgrade for Matrix Vi Cushion \$50
- SFVF Fabric side Startex Fabric Upgrade for Matrix Vi Cushion \$50

BACK COVER REFERENCE GUIDE

Meshtex	Infection Control	Onyx	
Back	Meshtex	Infection	Onyx
High	STD	N/A	\$103
Elite/ Elite HD/Elite Deep	STD	\$103	N/A
Elite TR/ Elite TR HD	STD	\$103	N/A
PB/PB HD/PB Deep/PB HD Deep	STD	\$103	N/A

OTHER UPGRADABLE BACK OPTIONS

- EBSS Super Soft Foam for Elite Back Upgrade . . . \$103
- OCUHG Onyx Fabric Upgrade for High Backs. \$103
- WSCU Infection Control Cover for Elite/PB Backs . . . \$103
purchased with back
- WSC Infection Control Cover for Elite/PB Backs . . . \$150
purchased with without back
- CHIEB Chest Harness Interface Kit for Elite Back⁽¹⁾⁽²⁾ . \$103
- CHIEB Chest Harness Interface Kit for PB Back⁽¹⁾⁽²⁾ . . . \$52

1. Does not include the chest strap.
2. This Interface Kit is only Required for 4 point harnesses.



Dealer Name: _____

Dealer Account Number: _____

PO #: _____

Tag: _____

UPGRADABLE BACK OPTIONS

High Back 16" - 22" wide \$595^{NEW}

- | | | | |
|---------------------------------|---------------------------------|---------------------------------|---------------------------------|
| <input type="checkbox"/> HB1616 | <input type="checkbox"/> HB1618 | <input type="checkbox"/> HB1620 | <input type="checkbox"/> HB1716 |
| <input type="checkbox"/> HB1718 | <input type="checkbox"/> HB1720 | <input type="checkbox"/> HB1816 | <input type="checkbox"/> HB1818 |
| <input type="checkbox"/> HB1820 | <input type="checkbox"/> HB1916 | <input type="checkbox"/> HB1918 | <input type="checkbox"/> HB1920 |
| <input type="checkbox"/> HB2016 | <input type="checkbox"/> HB2018 | <input type="checkbox"/> HB2020 | <input type="checkbox"/> HB2116 |
| <input type="checkbox"/> HB2118 | <input type="checkbox"/> HB2120 | <input type="checkbox"/> HB2216 | <input type="checkbox"/> HB2218 |
| <input type="checkbox"/> HB2220 | | | |

Matrix Elite Back 14" - 20" wide (3" Contour) \$766

- | | | | |
|----------------------------------|----------------------------------|----------------------------------|----------------------------------|
| <input type="checkbox"/> PBE1414 | <input type="checkbox"/> PBE1416 | <input type="checkbox"/> PBE1418 | <input type="checkbox"/> PBE1420 |
| <input type="checkbox"/> PBE1514 | <input type="checkbox"/> PBE1516 | <input type="checkbox"/> PBE1518 | <input type="checkbox"/> PBE1520 |
| <input type="checkbox"/> PBE1614 | <input type="checkbox"/> PBE1616 | <input type="checkbox"/> PBE1618 | <input type="checkbox"/> PBE1620 |
| <input type="checkbox"/> PBE1714 | <input type="checkbox"/> PBE1716 | <input type="checkbox"/> PBE1718 | <input type="checkbox"/> PBE1720 |
| <input type="checkbox"/> PBE1814 | <input type="checkbox"/> PBE1816 | <input type="checkbox"/> PBE1818 | <input type="checkbox"/> PBE1820 |
| <input type="checkbox"/> PBE1916 | <input type="checkbox"/> PBE1918 | <input type="checkbox"/> PBE1920 | <input type="checkbox"/> PBE2014 |
| <input type="checkbox"/> PBE2016 | <input type="checkbox"/> PBE2018 | <input type="checkbox"/> PBE2020 | |

Matrix Elite HD Back 21" - 22" wide (3" Contour) \$1,095

- | | | |
|-------------------------------------|-------------------------------------|-------------------------------------|
| <input type="checkbox"/> PBE2116-HD | <input type="checkbox"/> PBE2120-HD | <input type="checkbox"/> PBE2216-HD |
| <input type="checkbox"/> PBE2220-HD | | |

Matrix Elite Deep Back 14" - 20" wide (3" Contour) \$918

- | | | | |
|----------------------------------|----------------------------------|----------------------------------|----------------------------------|
| <input type="checkbox"/> EDB1416 | <input type="checkbox"/> EDB1418 | <input type="checkbox"/> EDB1420 | <input type="checkbox"/> EDB1514 |
| <input type="checkbox"/> EDB1516 | <input type="checkbox"/> EDB1518 | <input type="checkbox"/> EDB1520 | <input type="checkbox"/> EDB1614 |
| <input type="checkbox"/> EDB1616 | <input type="checkbox"/> EDB1618 | <input type="checkbox"/> EDB1620 | <input type="checkbox"/> EDB1714 |
| <input type="checkbox"/> EDB1716 | <input type="checkbox"/> EDB1718 | <input type="checkbox"/> EDB1720 | <input type="checkbox"/> EDB1814 |
| <input type="checkbox"/> EDB1816 | <input type="checkbox"/> EDB1818 | <input type="checkbox"/> EDB1820 | <input type="checkbox"/> EDB1914 |
| <input type="checkbox"/> EDB1916 | <input type="checkbox"/> EDB1918 | <input type="checkbox"/> EDB1920 | <input type="checkbox"/> EDB2014 |
| <input type="checkbox"/> EDB2016 | <input type="checkbox"/> EDB2018 | <input type="checkbox"/> EDB2020 | |

Matrix Elite Deep HD Back 21" - 22" wide (6" Contour). \$1,095

- | | | |
|-------------------------------------|-------------------------------------|-------------------------------------|
| <input type="checkbox"/> EDB2116-HD | <input type="checkbox"/> EDB2120-HD | <input type="checkbox"/> EDB2216-HD |
| <input type="checkbox"/> EDB2220-HD | | |

^{NEW} Matrix Elite E2 Back 14" - 20" wide/14"/16"H(3" Contour) . \$965

- | | | | |
|----------------------------------|----------------------------------|----------------------------------|----------------------------------|
| <input type="checkbox"/> E2S1414 | <input type="checkbox"/> E2S1416 | <input type="checkbox"/> E2S1514 | <input type="checkbox"/> E2S1516 |
| <input type="checkbox"/> E2S1614 | <input type="checkbox"/> E2S1616 | <input type="checkbox"/> E2S1714 | <input type="checkbox"/> E2S1716 |
| <input type="checkbox"/> E2S1814 | <input type="checkbox"/> E2S1816 | <input type="checkbox"/> E2S1914 | <input type="checkbox"/> E2S1916 |
| <input type="checkbox"/> E2S2014 | <input type="checkbox"/> E2S2016 | | |

^{NEW} Matrix Elite E2 Back 14" - 20" wide/18"/20"H(3" Contour) \$995

- | | | | |
|----------------------------------|----------------------------------|----------------------------------|----------------------------------|
| <input type="checkbox"/> E2S1418 | <input type="checkbox"/> E2S1420 | <input type="checkbox"/> E2S1518 | <input type="checkbox"/> E2S1520 |
| <input type="checkbox"/> E2S1618 | <input type="checkbox"/> E2S1620 | <input type="checkbox"/> E2S1718 | <input type="checkbox"/> E2S1720 |
| <input type="checkbox"/> E2S1818 | <input type="checkbox"/> E2S1820 | <input type="checkbox"/> E2S1918 | <input type="checkbox"/> E2S1920 |
| <input type="checkbox"/> E2S2018 | <input type="checkbox"/> E2S2020 | | |

^{NEW} Matrix Elite E2 Deep Back 14" - 20" wide/14"/16"H(6" Contour) \$1,125

- | | | | |
|----------------------------------|----------------------------------|----------------------------------|----------------------------------|
| <input type="checkbox"/> E2D1414 | <input type="checkbox"/> E2D1416 | <input type="checkbox"/> E2D1514 | <input type="checkbox"/> E2D1516 |
| <input type="checkbox"/> E2D1614 | <input type="checkbox"/> E2D1616 | <input type="checkbox"/> E2D1714 | <input type="checkbox"/> E2D1716 |
| <input type="checkbox"/> E2D1814 | <input type="checkbox"/> E2D1816 | <input type="checkbox"/> E2D1914 | <input type="checkbox"/> E2D1916 |
| <input type="checkbox"/> E2D2014 | <input type="checkbox"/> E2D2016 | | |

UPGRADABLE BACK OPTION

Matrix Elite E2 Deep Back 14" - 20" wide/18"/20"H (6" Contour) \$1,155

- | | | | |
|----------------------------------|----------------------------------|----------------------------------|----------------------------------|
| <input type="checkbox"/> E2D1418 | <input type="checkbox"/> E2D1420 | <input type="checkbox"/> E2D1518 | <input type="checkbox"/> E2D1520 |
| <input type="checkbox"/> E2D1618 | <input type="checkbox"/> E2D1620 | <input type="checkbox"/> E2D1718 | <input type="checkbox"/> E2D1720 |
| <input type="checkbox"/> E2D1818 | <input type="checkbox"/> E2D1820 | <input type="checkbox"/> E2D1918 | <input type="checkbox"/> E2D1920 |
| <input type="checkbox"/> E2D2018 | <input type="checkbox"/> E2D2020 | | |

Matrix Elite TR Back 15" - 20" wide (3" Contour)..... \$866

- | | | |
|-------------------------------------|-------------------------------------|-------------------------------------|
| <input type="checkbox"/> PBE1516-TR | <input type="checkbox"/> PBE1518-TR | <input type="checkbox"/> PBE1520-TR |
| <input type="checkbox"/> PBE1616-TR | <input type="checkbox"/> PBE1618-TR | <input type="checkbox"/> PBE1620-TR |
| <input type="checkbox"/> PBE1716-TR | <input type="checkbox"/> PBE1718-TR | <input type="checkbox"/> PBE1720-TR |
| <input type="checkbox"/> PBE1816-TR | <input type="checkbox"/> PBE1818-TR | <input type="checkbox"/> PBE1820-TR |
| <input type="checkbox"/> PBE1916-TR | <input type="checkbox"/> PBE1918-TR | <input type="checkbox"/> PBE1920-TR |
| <input type="checkbox"/> PBE2016-TR | <input type="checkbox"/> PBE2018-TR | <input type="checkbox"/> PBE2020-TR |

Matrix Elite TR HD Back 21" - 22" wide (3" Contour) . . \$1,151

- | | |
|---------------------------------------|---------------------------------------|
| <input type="checkbox"/> PBE2120-TRHD | <input type="checkbox"/> PBE2220-TRHD |
|---------------------------------------|---------------------------------------|

Matrix PB Posture Back 14" - 20" wide (5" Contour) \$734

- | | | | |
|----------------------------------|----------------------------------|----------------------------------|----------------------------------|
| <input type="checkbox"/> MPB1412 | <input type="checkbox"/> MPB1612 | <input type="checkbox"/> MPB1616 | <input type="checkbox"/> MPB1620 |
| <input type="checkbox"/> MPB1712 | <input type="checkbox"/> MPB1716 | <input type="checkbox"/> MPB1720 | <input type="checkbox"/> MPB1812 |
| <input type="checkbox"/> MPB1816 | <input type="checkbox"/> MPB1820 | <input type="checkbox"/> MPB2012 | <input type="checkbox"/> MPB2016 |
| <input type="checkbox"/> MPB2020 | | | |

Matrix PB Posture Back Deep 14" - 20" wide (7" Contour) . \$892

- | | | | |
|----------------------------------|----------------------------------|----------------------------------|----------------------------------|
| <input type="checkbox"/> PBD1412 | <input type="checkbox"/> PBD1612 | <input type="checkbox"/> PBD1616 | <input type="checkbox"/> PBD1620 |
| <input type="checkbox"/> PBD1712 | <input type="checkbox"/> PBD1716 | <input type="checkbox"/> PBD1720 | <input type="checkbox"/> PBD1812 |
| <input type="checkbox"/> PBD1816 | <input type="checkbox"/> PBD1820 | <input type="checkbox"/> PBD2012 | <input type="checkbox"/> PBD2016 |
| <input type="checkbox"/> PBD2020 | | | |

Matrix PB Heavy Duty Back 20" - 22" wide (5" Contour) . \$1,051

- | | | | |
|----------------------------------|----------------------------------|----------------------------------|----------------------------------|
| <input type="checkbox"/> HDB2016 | <input type="checkbox"/> HDB2020 | <input type="checkbox"/> HDB2216 | <input type="checkbox"/> HDB2220 |
|----------------------------------|----------------------------------|----------------------------------|----------------------------------|

Matrix PB Heavy Duty Deep Back 20"-22" wide (5" Contour) \$1,209

- | | | | |
|-----------------------------------|-----------------------------------|-----------------------------------|-----------------------------------|
| <input type="checkbox"/> DHDB2016 | <input type="checkbox"/> DHDB2020 | <input type="checkbox"/> DHDB2216 | <input type="checkbox"/> DHDB2220 |
|-----------------------------------|-----------------------------------|-----------------------------------|-----------------------------------|



Dealer Name: _____

Dealer Account Number: _____

PO #: _____

Tag: _____

MATRIX ELAN HEADREST PAD⁽¹⁾⁽²⁾

<input type="checkbox"/> ESP6	Matrx Elan Standard Pad 6"	\$310
<input type="checkbox"/> ESP10	Matrx Elan Standard Pad 10"	\$310
<input type="checkbox"/> ESP14	Matrx Elan Standard Pad 14"	\$310
<input type="checkbox"/> EOP9	Matrx Elan Occipital Pad 9"	\$341
<input type="checkbox"/> EOP12	Matrx Elan Occipital Pad 12"	\$341
<input type="checkbox"/> E4PTSM	Matrx Elan 4-Point Pad 9"W x 7"H	\$448
<input type="checkbox"/> E4POINT	Matrx Elan 4-Point Pad 11"W x 10"H	\$448
<input type="checkbox"/> ESP6-IC	Matrx Elan Standard Pad 6" with Infection Control	\$335
<input type="checkbox"/> ESP10-IC	Matrx Elan Standard Pad 10" with Infection Control	\$335
<input type="checkbox"/> ESP14-IC	Matrx Elan Standard Pad 14" with Infection Control	\$335
<input type="checkbox"/> EOP9-IC	Matrx Elan Occipital Pad 9" with Infection Control	\$366
<input type="checkbox"/> EOP12-IC	Matrx Elan Occipital Pad 12" with Infection Control	\$366
<input type="checkbox"/> E4PTSM-IC	Matrx Elan 4-Point Pad 9"W x 7"H with Infection Control	\$473
<input type="checkbox"/> E4POINT-IC	Matrx Elan 4-Point Pad 11"W x 10"H with Infection Control	\$473

1. Not compatible with sling back (ASBA-2)
 2. If mounting on PB Elite must order removable hardware

HEADREST MOUNTING HARDWARE OPTIONS

<input type="checkbox"/> LXSHW	LOXX Standard Hardware with 15" Vertical Post	\$275
<input type="checkbox"/> LXMMH	LOXX Mini Hardware with 11" Vertical Post	\$275
<input type="checkbox"/> MEHWRE	Elan Multi-Axis Removable HDW	\$285

1. Only compatible w/Standard Rehab, Contour & High Back Models. All other head rests REQUIRE an upgrade to Removable Hardware.

MATRIX FIXED LATERALS - FOR ELITE AND ELITE TR BACKS

<input type="checkbox"/> PBSSL	Matrx Small Lateral Fixed-Left(3x5.5")	\$113
<input type="checkbox"/> PBSSR	Matrx Small Lateral Fixed-Right(3x5.5") . . .	\$113
<input type="checkbox"/> PBLSL	Matrx Standard Lateral Fixed-Left(7.5x5") .	\$116
<input type="checkbox"/> PBLSR	Matrx Standard Lateral Fixed-Right (7.5x5")	\$116
<input type="checkbox"/> PBOLL	Matrx Offset Lateral Fixed Left	\$125
<input type="checkbox"/> PBOLR	Matrx Offset Lateral Fixed Right	\$125

MATRIX SWING AWAY LATERALS - FOR ELITE AND ELITE TR BACKS

Matrx Lateral Trunk Support Left ⁽¹⁾		
<input type="checkbox"/> EPADXL	Size XS (3.25x4.25")	\$115
<input type="checkbox"/> EPADSL	Size S (3.5x5.25")	\$115
<input type="checkbox"/> EPADML	Size M (3.75x5.75")	\$115
<input type="checkbox"/> EPADLL	Size L (4.25x6.5")	\$115
Matrx Lateral Trunk Support Right ⁽¹⁾		
<input type="checkbox"/> EPADXR	Size XS (3.25x4.25")	\$115
<input type="checkbox"/> EPADSR	Size S (3.5x5.25")	\$115
<input type="checkbox"/> EPADMR	Size M (3.75x5.75")	\$115
<input type="checkbox"/> EPADLR	Size L (4.25x6.5")	\$115

1. Must choose swing away hardware below

MATRIX SWING AWAY HARDWARE - FOR ELITE AND ELITE TR BACKS

<input type="checkbox"/> SAEHBL	Matrx Elite Swing Away Hardware Left	\$250
<input type="checkbox"/> SAHEBR	Matrx Elite Swing Away Hardware Right	\$250
<input type="checkbox"/> OSAHL	Matrx Offset Elite Swing Away Hardware Left	\$250
<input type="checkbox"/> OSAHR	Matrx Offset Elite Swing Away Hardware Right	\$250

Maxx Rehab Seat on Invacare TDX-SP2 Base

Dealer Name: _____

Dealer Account Number: _____

PO #: _____

Tag: _____

MAXX LATERALS TRUNK SUPPORTS⁽¹⁾

Left Fixed Mount Lateral Trunk Support⁽¹⁾

Select Left Trunk Support Size

- LATXL Size XS (3.25" x 4.25") \$100
- LATSL Size S (3.5" x 5.25") \$100
- LATML Size M (3.75" x 5.75") \$100
- LATLL Size L (4.25" x 6.5") \$100

Right Fixed Mount Lateral Trunk Support⁽¹⁾

Select Right Trunk Support Size

- LATXR Size XS (3.25" x 4.25") \$100
- LATSR Size S (3.5" x 5.25") \$100
- LATMR Size M (3.75" x 5.75") \$100
- LATLR Size L (4.25" x 6.5") \$100

1. These laterals are not available with Matrix PB, PB Elite Deep and PB Deep Backs.

MAXX STYLE SWING-AWAY TRUNK SUPPORT HARDWARE⁽¹⁾

- SALATL Left MAXX Style Swing Away HDW \$195

Select Left Trunk Support Size

- LATXL Size XS (3.25" x 4.25") \$100
- LATSL Size S (3.5" x 5.25") \$100
- LATML Size M (3.75" x 5.75") \$100
- LATLL Size L (4.25" x 6.5") \$100

- SALATR Right MAXX Style Swing Away HDW⁽¹⁾ . . . \$195

Select Right Trunk Support Size

- LATXR Size XS (3.25" x 4.25") \$100
- LATSR Size S (3.5" x 5.25") \$100
- LATMR Size M (3.75" x 5.75") \$100
- LATLR Size L (4.25" x 6.5") \$100

- ATLL Additional Telescoping Link - Left⁽²⁾ . . . \$75

- ATLR Additional Telescoping Link - Right⁽²⁾ . . \$75

1. These laterals are not available with Matrix PB, PB Elite Deep and PB Deep Backs
2. Up to 2.75" medial offset

FIXED HIP/ KNEE SUPPORTS

Lateral Hip Support with Fixed Mounting Hardware Left⁽¹⁾

Select Pad Size and mounting position at Hip:

- HSPXLH Size XS (5.5" W x 4" H) mounted at Hip . \$120
- HSPSLH Size S (7" W x 6" H) mounted at Hip . . . \$120
- HSPMLH Size M (9" W x 4" H) mounted at Hip . . . \$120
- HSPLLH Size L (13" W x 4" H) mounted at Hip . . . \$120

Select Pad Size and mounting position at Knee:

- HSPXLK Size XS (5.5" W x 4" H) mounted at Knee . . . \$120
- HSPSLK Size S (7" W x 6" H) mounted at Knee \$120
- HSPMLK Size M (9" W x 4" H) mounted at Knee \$120
- HSPLLK Size L (13" W x 4" H) mounted at Knee \$120

FIXED HIP/ KNEE SUPPORTS - CONTINUED

Lateral Hip Support with Fixed Mounting Hardware Right⁽¹⁾

Select Pad Size and mounting position:

- HSPXRH Size XS (5.5" W x 4" H) mounted at Hip . . . \$120
- HSPSRH Size S (7" W x 6" H) mounted at Hip \$120
- HSPMRH Size M (9" W x 4" H) mounted at Hip \$120
- HSPLRH Size L (13" W x 4" H) mounted at Hip \$120

Select Pad Size and mounting position at Knee:

- HSPXRK Size XS (5.5" W x 4" H) mounted at Knee . . . \$120
- HSPSRK Size S (7" W x 6" H) mounted at Knee \$120
- HSPMRK Size M (9" W x 4" H) mounted at Knee \$120
- HSPLRK Size L (13" W x 4" H) mounted at Knee \$120

1. Must choose swing away hardware below if required.

REMOVABLE HIP/ KNEE SUPPORT HARDWARE

Lift Off Removable Hardware for Hip Support

- LOHL Left \$195
- LOHR Right \$195

MAXX Style Quick Release, Removable, Multi-Axis Mounting Hardware for Hip Supports

Select mounting position:

- MSHSLH Left mounted at Hip \$215
- MSHSLK Left mounted at Knee \$215
- MSHSRH Right mounted at Hip \$215
- MSHSRK Right mounted at Knee \$215

Swing Away Removable Hardware for Hip Supports

Select mounting position:

- SHSHLH Left mounted at Hip \$215
- SHSHLK Left mounted at Knee \$215
- SHSHRH Right mounted at Hip \$215
- SHSHRK Right mounted at Knee \$215

Extended Maxx Style Quick Release, Removable, Multi-Axis Mounting Hardware for Hip Supports⁽¹⁾

Select mounting position:

- EMQHLH Left mounted at Hip \$215
- EMQHLLK Left mounted at Knee \$215
- EMQHRH Right mounted at Hip \$215
- EMQHRLK Right mounted at Knee \$215

1. Recommended when finished seat cushion thickness will be greater than 3.5" high.